

**Assignment for Unit 8-5,
Assemblies in Section**

5. On a B (A3) size sheet, make a one-view section assembly drawing of one of the problems shown in Fig. 8-5-A or 8-5-B. Include on your drawing an item list and identify the parts on the assembly. Assuming that this drawing will be used in a catalog, place on the drawing the dimensions and information required by the potential buyer. Scale 1:1.

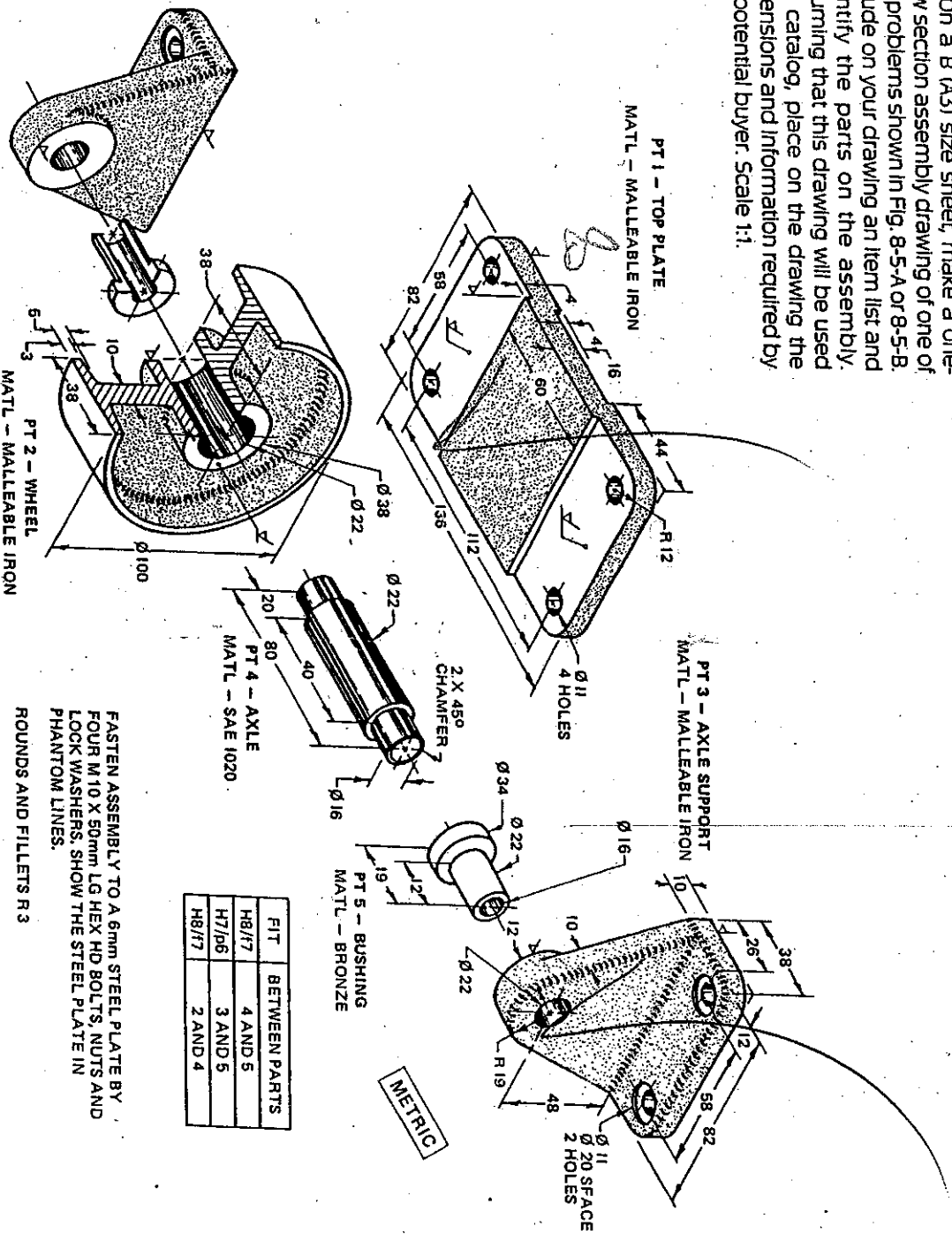

Fig. 8-5-A Castor.