

# Underwater Mini-ROV

Remote Operated Vehicle

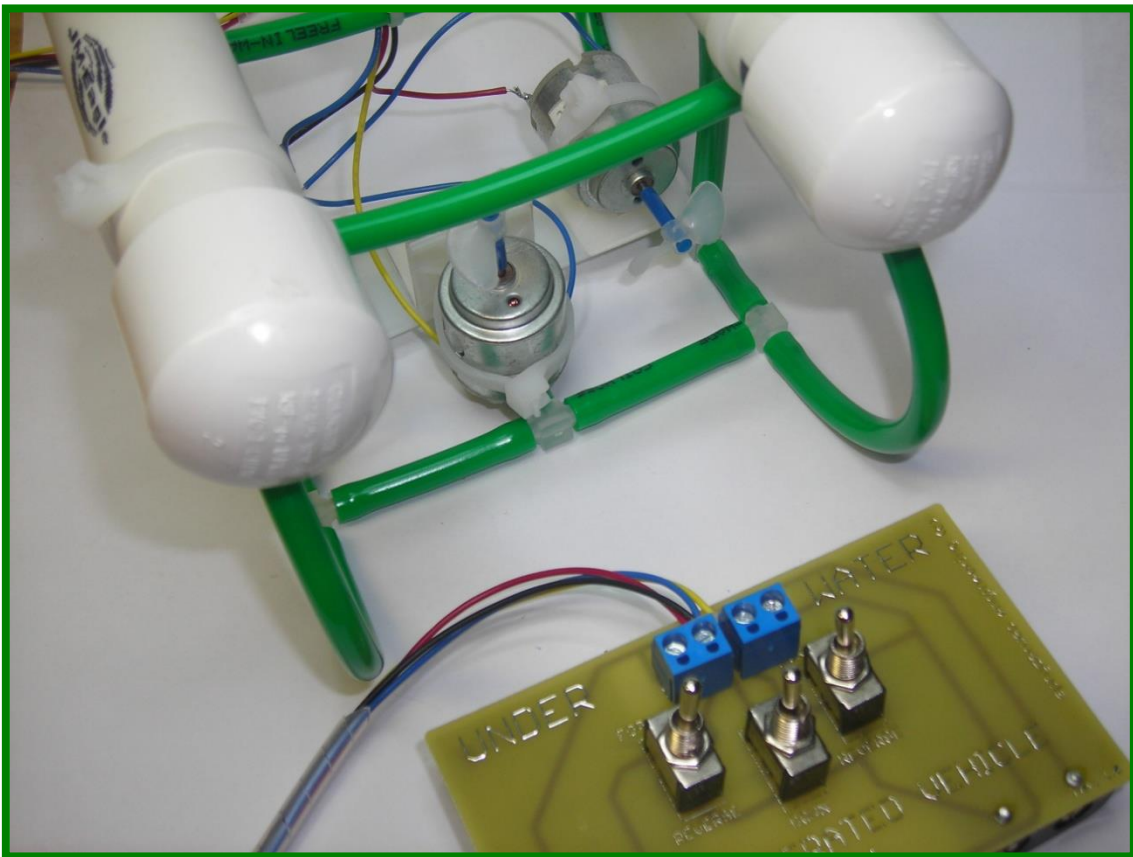

## Lesson/Activity Workbook

Written by:



## A WORD ABOUT THIS WORKBOOK

Underwater ROV's provide a fun and fascinating way for students to learn the rigor of math and science in a practical manner.

This workbook is meant to be an introduction to the operation of ROV's. It contains four lessons and six activities. The lessons topics include:

- Electricity
- Propulsion
- Buoyancy
- Speed Calculations

The lessons use the ROV as a model to introduce each topic. The activities involve practical applications illustrating the relevance of the underwater ROV world.

It is our hope that your interests in operating and understanding underwater ROV's will increase and you will continue to discover and learn about the many opportunities that exist in this exciting and growing field.

Here's a challenge....after you have mastered maneuvering and navigating this ROV, build another one on your own. Only this time make it bigger, make it go deeper and even give it a little eye! You never know what you may find under the surface of the water!

Happy Exploring!

**The spryderweb team**

### **IMPORTANT:**

- When running the ROV out of the water DO NOT operate it for more than 5 seconds.
- Always keep wires clear of props when operating out of water.
- Keep the control panel and batteries dry at all times.

# LESSON #1

## VOLTAGE, CURRENT AND RESISTANCE – THEY MAKE THE PROPS GO ROUND

### **Objective:**

To understand why voltage, current and resistance are required elements in the propulsion of the ROV.

### **Theory of Operation:**

To quote an engineer characterized in a popular movie, “Current is everything gentlemen, without it we have nothing”. (*Apollo 13*) This statement could not be closer to the truth. Current is what makes lights turn on, computers calculate and i-Pods play music. Without it we would still be in the dark. So where does it come from and why do we need it to power our ROV?

Let's start by defining a few important terms. Voltage is defined as an electric potential. Current is defined as the flow of electrons through a conductor (wire). Resistance is defined as a measure to which an object opposes an electric current through it. Individually, these definitions can be confusing but put them together and what you get can light the world. Let's first explain the relationship between these terms this way: Let's say that a typical garden hose is your conductor (wire). Current is the water that flows through the hose. Voltage is the spigot to which the hose is attached. That is, it controls the rate at which water flows. And resistance is a kink in the hose that restricts the flow of water. So if the spigot is turned off there is no water flowing through the hose. But if the spigot is turned on, the pressure moving the water is like voltage. The water moving through the hose is like flowing electrons or current. And if you put a kink in the hose, it acts as a resistor, restricting the amount of water or current that flows through the hose. Got it?

The mathematical relationship between voltage, current and resistance is called Ohm's Law and is defined as:  $V$  (volts) =  $I$  (current) x  $R$  (resistance) Note: Many texts use the letter  $E$  to represent volts. In our workbook we will use the letter  $V$ .

Try this:

A typical flashlight needs .3 amps of current to turn on the bulb and the bulb has a resistance of 10 ohms. What voltage would be required to operate the flashlight? Using Ohm's Law we would have:

$$V = I \times R = .3 \times 10 = 3 \text{ volts}$$

That's right....a 3 volt battery.

### **Needed:**

Volt-ohm meter

## Procedure:

Now that we have an understanding of Ohm's Law, let's take some measurements and make some calculations using your ROV.

1 – Make sure the ROV is functional. Flip each switch and make sure each motor turns correctly. Place the ROV so that it is facing away from you. The tether should be facing you.

2 – Starting with the motor on the left, place the meter probes on the tabs of the motor. (One probe of each) Now turn on the left forward/reverse switch. You should now see a voltage measurement on the meter. Record the measurement.

3 – Continue the same procedure for each motor and its relative switch. Record all voltage measurements as motor 1, 2 and 3.

4 – Now let's measure resistance. We will be measuring the resistance through one of the motors. Make sure that the batteries are removed before taking measurements.

5 – Make sure the meter is set to measure resistance. Place a probe on one of the blue motor wires. Place the other probe on the opposite motor tab. You should now be reading the resistance through the motor windings. Record each resistance measurement as R1, R2 and R3. Each corresponding to its proper motor.

6 – Now that we have voltage and resistance for each motor, let's calculate current for each motor using Ohm's Law.

7 – Since we want to find current we have to modify the equation, therefore  $I = V / R$ .

8 – Calculate and record the current for each motor.

## Analysis:

1. List the three main elements of any electronic circuit.
2. What is the definition of current?
3. What is the definition of voltage?
4. If a toaster has a resistance of 100 ohms and a current of 1.2 amps, what is the voltage?
5. If a calculator uses a 1.5 volt battery with a resistance of 10 ohms, how much current is required?

## LESSON #2

### DOES PROPULSION MAKE IT FLY?

#### **Objective:**

To understand how the ROV moves through the water.

#### **Theory of Operation:**

The word “propulsion” can be used in many different arenas: vehicle, air, spacecraft and marine are just a few of the applications that use propulsion. Propulsion is defined as the action or process of propelling. I’m sure sometime in your life you have skipped a rock across the water. You propelled that rock or gave it propulsion. What about when you jumped over the fence in your backyard. You propelled yourself over the fence.

Vehicles use propulsion when they transport people or goods across a distance. Airplanes use jet engines to propel themselves across the sky. The space shuttle uses a rocket engine to propel itself into space. As with other marine vehicles, your ROV uses a propeller to propel itself through the water.

Since your ROV travels underwater and not on top it is important to understand how it moves. Let’s first relate it to an airplane that used a propeller. An airplane usually has one or two propellers that move it through the air at a given speed. When the airplane wants to turn left or right or move up or down it has to use other controls such as ailerons or elevators. Not so with your ROV. Your ROV uses propellers to move it in all six possible directions. But why?

Propellers either push the water or pull the water. In order to go forward the propeller pulls the water toward itself creating a flow of water that propels the ROV forward. Likewise in order to go backward the propeller pushes the water away from itself creating a flow of water that propels the ROV backward.

The same action is required for the ROV to travel up and down.

#### **Needed:**

Strips of paper approximately one inch wide and six inches long

## Procedure:

Now that we have an understanding of how a propeller works, let's do an experiment. This will be done out of the water.

1 – Place the ROV on a flat surface such as a table or floor. Make sure the ROV is functional by flipping the switches.

2 – Situate the ROV so that you are facing the side.

3 – Holding the piece of paper at one end, place the other end approximately 1 inch from the propeller. Do this from the side of the ROV.

4 – Turn on the motor in the reverse direction and observe what happens to the end of the paper. The paper should curl away from the propeller. This would indicate that the propeller is pushing air into the paper and therefore propelling itself backward.

5 – Now turn on the motor in the forward direction and observe what happens to the end of the paper. The paper should curl toward the propeller. This would indicate that the propeller is pulling air toward itself and therefore pulling that paper. This action would propel the ROV forward.

6 – Complete the same procedure for the up/down motor. Did you notice that the paper does not curl as much as it did in steps 4 and 5? That's because of gravity, a lesson for another day!

7 – Now place your ROV in a sink filled with water. Submerge the ROV to just over the motors. Now turn on the motors and observe what happens.

8 – With the forward/reverse motors just barely under the surface of the water, switch the motor in the forward position. You should observe the water being pulled. Likewise when the motor is switched to the reverse position you should observe the water being pushed.

## Analysis:

1. Define propulsion.
2. What is used to propel a space craft into space?
3. What is the common device used in airplanes and your ROV?
4. How many possible directions can your ROV travel? What are they?
5. Explain briefly how your ROV propels itself through the water?

## LESSON #3

### BOUYANCY.....MAKING IT NEUTRAL

#### **Objective:**

To understand the role of neutral buoyancy in an ROV

#### **Theory of Operation:**

Ever wonder how a ten ton Navy submarine dives and surfaces almost effortlessly? What causes it to dive? How can an object of that weight come back to the surface? The secret....buoyancy!

There are three states of buoyancy, positive, negative, and neutral. To understand the concept of positive buoyancy, think of being in a swimming pool while holding a life jacket. You would *float* to the top of the surface. Now let go of the life jacket and exhale. You now are experiencing negative buoyancy and would *sink* to the bottom of the pool. The ideal buoyancy is slightly positive. This would allow an ROV to float back to the surface at a very slow rate.

Neutral buoyancy does not allow your ROV to sink or float while underwater. This is accomplished by the scientific concept of density. The closer your ROV density is to the density of water the closer your ROV is to neutral buoyancy. Therefore in order to go from neutral to negative or neutral to positive the density of the ROV must change. This can be accomplished by adding or reducing weight.

In the case of the Navy submarines, water can be pulled into or pushed out of what are called ballast tanks. Ballast tanks are usually located along the bottom of the submarine. By pulling in water, the density of the submarine increases and approaches negative buoyancy therefore sinking. By pushing water out of the ballast tanks, the density of the submarine decreases and approaches positive buoyancy therefore rising to the surface.

#### **Needed:**

Pennies

Various sized nuts

Various sized washers

## Procedure:

Now that we understand the idea of buoyancy let's apply it to your ROV. With a little trial and error we can make your ROV buoyant. This experiment will take place in water.

- 1 – Prepare a sink or tub with at least 8 inches of water. You need to have enough depth to gauge whether or not you achieve neutral buoyancy.
- 2 – Remove the end caps from the ballast tanks and place one each of the same objects into each of the tanks. It might be good to start with 2 pennies in each tank.
- 3 – Place the ROV in the water and observe whether it sinks or floats.
- 4 – If the ROV sinks, too much weight has been added and you now have negative buoyancy. To move closer to neutral buoyancy reduce the weight and test again.
- 5 – If the ROV floats, not enough weight was added and you now have positive buoyancy. To move closer to neutral buoyancy add more weight and test again.
- 6 – The closer you get to neutral buoyancy the lighter the material you should use. This will fine tune your ROV toward neutral buoyancy.

## Analysis:

1. What would happen if you only loaded one of the ballast tanks?
2. What happens if the weight shifts in the ballast tanks?
3. What impact would the location of the ballast tanks have on the control of the ROV?
4. Define neutral buoyancy.

## LESSON #4

### HOW FAST WILL IT GO.....CAN I CATCH A FISH?

#### **Objective:**

To determine, through calculation and measurement, the speed of your ROV.

#### **Theory of Operation:**

Ask any NASCAR driver and they will tell you, "Speed is king". Without it, you don't get sponsors or the winners circle. But before you can tell someone their speed, you first must be able to determine it. Police officers use radar guns. You are going to use the age-old method of distance and time.

Speed is a factor of distance divided by time. Cars travel in miles per hour (miles divided by hour.) Many other speeds are determined by feet per second (feet divided by seconds.) Since your ROV does not travel as fast as a car, we will be using feet per second.

To determine speed two measurements must be taken. The first would be the distance from point A to point B which the object is traveling. Second would be the time it takes for the object to get from point A to point B.

For example, if a teenager on a skateboard was traveling down a sidewalk we could determine his speed. Let's say he starts at a driveway, skates past the next driveway then stops shortly after the third driveway. If we knew the distance between the second and third driveway was 200 feet and it took him 20 seconds to go from the second to third driveway we have enough information to determine his speed. Remember speed is the distance divided by the time. Therefore, the teenager's speed would be 200 feet divided by 20 seconds or 10 feet/second.

Notice we did not *start* timing the teenager from a stopped position but rather moving. Had we started the timer from a stopped position to a distance farther away we would have calculated acceleration and that's for another day!

#### **Needed:**

Stop watch

Tape measure

Calculator

Tape or some other way to mark underwater

Second set of hands

Tub

## Procedure:

Now that you understand how to calculate speed using distance and time let's set up a course to determine the speed of your ROV.

1 – On the edge of a tub nearest to the drain put a piece of tape (start line). Now measure one foot and place another piece of tape (start timing line). Measure two feet from there and place a third piece of tape (end timing line).

2 – Place the ROV at the start line. Take a few practice trials before you begin. Your goal is to go as straight as possible from the start line to the end timing line.

3 – Now place the ROV back on the starting line. Move the ROV in a forward direction. As soon as the ROV reaches the start timing line have a person start the stop watch. When the ROV reaches the end timing line stop the stop watch. This will give you the time it takes to go from the start line to the end line.

4 – Complete the above step 4 times and record the times below.

Trial #1 \_\_\_\_\_  
Trial #2 \_\_\_\_\_  
Trial #3 \_\_\_\_\_  
Trial #4 \_\_\_\_\_

5 – Now take the distance of 2 feet and divide it by each of the times.

Speed #1 \_\_\_\_\_ ft/s  
Speed #2 \_\_\_\_\_ ft/s  
Speed #3 \_\_\_\_\_ ft/s  
Speed #4 \_\_\_\_\_ ft/s

6 – Add the four speeds together and divide by four to get the average speed.

Average Speed \_\_\_\_\_ ft/s

## Analysis:

1. Why wouldn't you start timing from the stopped position?
2. If a car travels 500 miles in 12 hours, what was its speed?
3. What changes could be made to make the ROV faster?
4. How would the speed change if the ROV was going against the current?

## ACTIVITY OBJECTIVE

To fine tune the skills needed in order to navigate an underwater course.



Underwater ROV's are used for rescue and exploratory purposes. Maneuvering and navigating an ROV underwater is essential to the success of any mission.

During the exploration of Titanic, ROV's were used to explore different levels of the ship, most of which could not be reached by a manned submarine. Maneuvering and navigating thousands of feet below the surface takes lots of practice and patience.

In the next several activities you will be asked to create several "courses". Each course will test a different maneuvering or navigating skill. Don't get discouraged. Master one activity before going to the next. By the end, you will be a master at maneuvering and navigation.

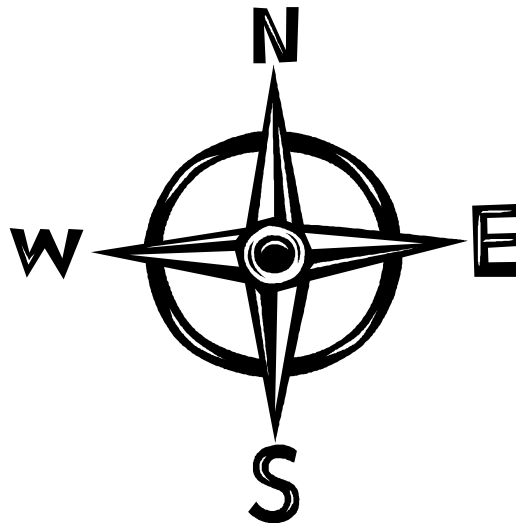

## ACTIVITY #5

### STEADY AS SHE GOES

Sometimes it is necessary to make wide sweeping turns with your ROV. This activity will improve your skills at maneuvering those turns.

#### Procedure:

1 – Use masking tape to layout the following course on the bottom of your tub. Fill the tub with at least 10 inches of water. (Your course size may vary depending on the size of your tub)

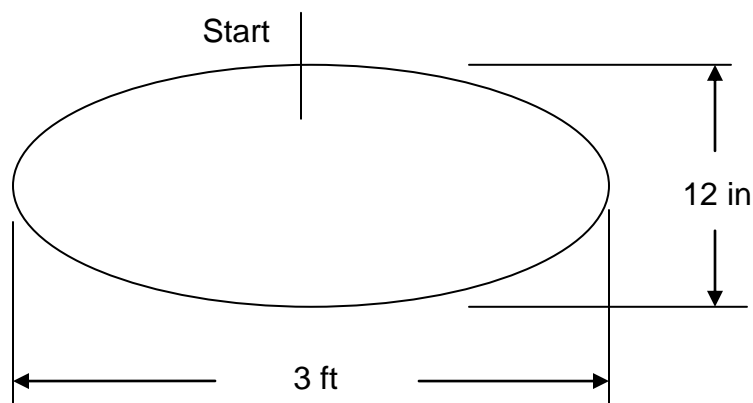

2 – Starting at the top, practice maneuvering all around the entire oval. Attempt to keep the ROV centered on the tape. Practice this several times before going to the next step.

3 – Now that you're proficient at maneuvering the oval, let's calculate your speed. Measure the total length of the oval using a tape measure.

4 – With the help of a second person record the amount of time it takes to complete one lap.

5 – Refer to Lesson #4 to calculate your speed.

6 – Try this several times recording your speed after each attempt. Hopefully you will see an improvement.

## ACTIVITY #6

### TURNING ON A DIME

Precision control of your ROV requires practice. An important skill to master is  $0^\circ$  turning or “turning on a dime”. Newer lawn mowers implement the same type of turning with one main difference; they DO NOT have a tether attached. Turning on a dime can be tricky but with the right amount of practice can be mastered.

#### Procedure:

1 – Place five dimes in a pattern on the bottom of a tub as shown below. Fill the tub with 10 inches of water.

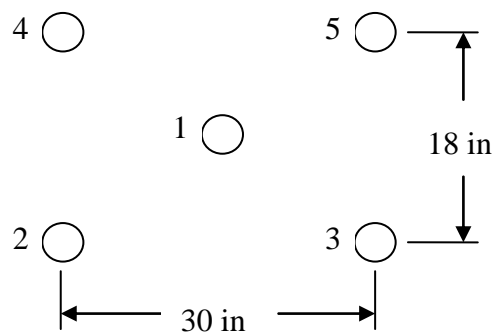

2 – Place the ROV on dime #1. The ROV should be facing away from you.

3 – While hovering over dime #1, perform a  $0^\circ$  turn and navigate the ROV to dime #2. Set the ROV on dime #2 facing away from you. While performing the  $0^\circ$  turn the ROV should remain over the dime.

4 – Hover over dime #2, perform a  $0^\circ$  turn and navigate the ROV to dime #3. Set the ROV on dime #3 facing toward you.

5 – Hover over dime #3, perform a  $0^\circ$  turn and navigate the ROV to dime #4. Set the ROV on dime #4 facing toward you.

6 – Hover over dime #4, perform a  $0^\circ$  turn and navigate the ROV to dime #5. Set the ROV on dime #5 facing toward dime #1.

7 – Hover over dime #5 and return the ROV to dime #1 facing away from you.

8 – Repeat steps 2 through 7 until you are proficient at navigating the ROV around the course.

#### Note:

As an added activity, record each time it takes you to navigate the course and compare the times. Hopefully you're getting better!

## ACTIVITY #7

### SHARP TURNS

In the last activity you learned how to turn the ROV 360°. Another important maneuver is the 90° turn. When the ROV used to explore the Titanic maneuvered around the rooms it had to make tight turns to avoid debris. This maneuver is vital in order to navigate in tight quarters.

#### Procedure:

1 – Use masking tape to layout the following course on the bottom of your tub. Fill the tub with at least 10 inches of water. (Your course size may vary depending on the size of your tub.)

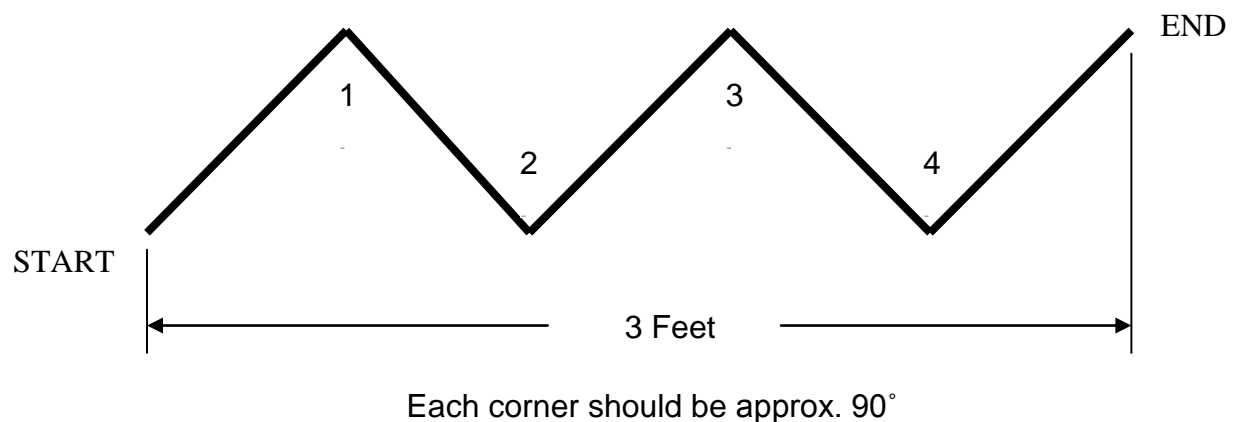

2 – Place the ROV at the start of the course facing away from the first turn.

3 – Hover over the start and maneuver the ROV to turn #1. Keep the ROV centered over the line at all times.

4 – Make a 90° turn and continue to turn #2.

5 – Continue making the 90° turns until you reach the end of the course.

#### Note:

As an added activity record each time it takes you to navigate the course and compare the times. Hopefully you're getting better!

## ACTIVITY #8

### UNDERWATER OBSTACLES

Now that you have mastered the art of navigating your ROV, let's create an obstacle course. To create the course you will need to acquire six (plastic water bottles? (12 to 20oz) filled with sand and water. (the more sand the better and make sure the tops are tight.

#### Procedure:

1 – Although you could place the bottles in any pattern you want on the bottom of your tub, start with the pattern given below. Begin with the bottles spaced apart to the maximum your tub will allow.

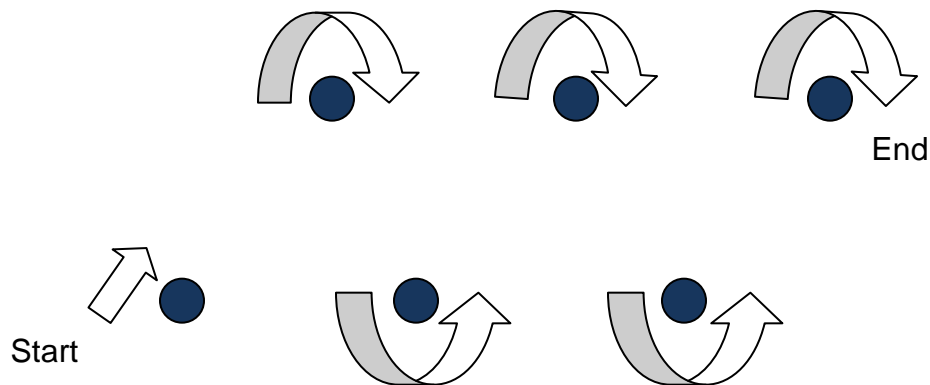

2 – Place the ROV at the start bottle and follow the direction of the arrows.

3 – Try not to knock down or touch any of the bottles. Keep an eye on your tether. Don't let it knock over the bottles.

4 – When you have gone from the start to the end, without stopping, turn around and go back through the course.

#### Note:

As you become better at navigating the obstacle course, move the bottles closer together. Remember to use all the skills you learned in previous lessons.

## ACTIVITY #9

### CAVE EXPLORATION

Most commercial ROV's, like the one used to explore Titanic, must navigate through close quarters and tight spots. For this activity we must first create an enclosed space or "tunnel" to navigate through. You may have something lying around the house that you could use to create a tunnel. If not, below is a diagram that will show how to make a tunnel out of PVC tubing.

#### Note:

You may need to drill holes in the PVC allowing water to enter the tubes.

#### Required parts:

Six - 10 inch pieces of ½ inch PVC tube

Two – 12 inch pieces of ½ inch PVC tube

Four – 3-way connectors for ½ inch PVC tube

#### Diagram:

Use the four 3-way connectors to assemble the tunnel as shown. The **two 12 inch** pieces will make up the length of the tunnel.

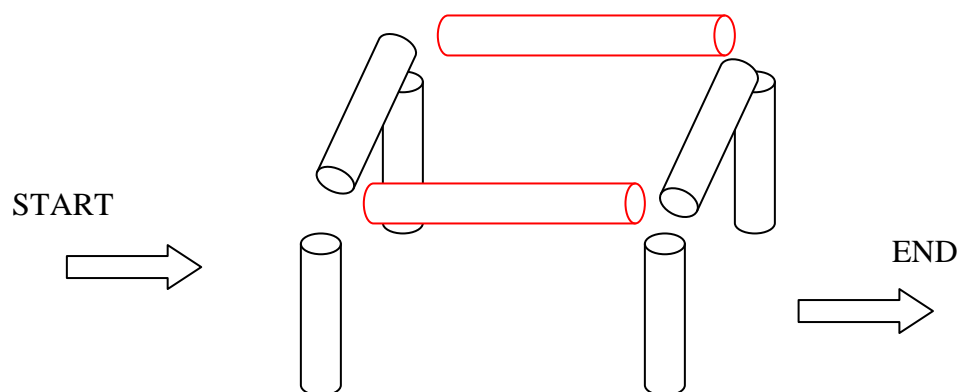

#### Procedure:

- 1 – Set the tunnel in the middle of the tub. Fill the tub with water to a level just above the tunnel.
- 2 – Starting at one end of the tunnel navigate the ROV through and out the other end.
- 3 – Without stopping, turn the ROV around and navigate the ROV back through the tunnel. WATCH THE TETHER!

#### Note:

If you have a tub that is deep enough try navigating the ROV through the top of the tunnel and out one of the sides. Then navigate back.

## ACTIVITY #10

### TREASURE HUNTING

Exploratory ROV's have mechanical arms and claws that can move or pick up debris on the ocean floor. It's exciting to see what's on the ocean floor but even more exciting to bring something back! In this activity you will make a slight modification to the ROV that will allow it to pick up "treasure" on the ocean or tub floor.

#### Required Parts:

Five Paper Clips

Two straws (1-2 inches long, 1-3 inches long)

Stapler

#### Make a hook:

The ROV must be equipped with a mechanism by which to pick items up. For simplicity sake we are going to create a simple hook from a paper clip and attach it to the bottom of the ROV. The pictures here illustrate how to bend the paper clip. As pictured, the hook is located in the front of the up/down motor bent around the front cross member.



#### Making treasure:

There are many different "treasures" that you can find on the bottom of your tub. Below is a picture of a "treasure" that can be easily made out of straws and paper clips. If made correctly it will stand up on the bottom of the bathtub.

Bend the three inch straw as shown in the picture and staple it to the top of the two inch piece. Attach four paper clips to add weight. Make more than one for an additional challenge.



#### Procedure:

1 – Toss the "treasure" into the bathtub. It should stand up on the bottom and the loop is at the top.

2 – Submerge your ROV into the water.....HAPPY HUNTING!